

SCXI™-1381K TERMINAL BLOCK HOUSING KIT

This guide explains how to assemble your SCXI-1381K terminal block housing kit and includes dimensions for designing your circuit boards.

Introduction

The SCXI-1381K is intended for developers of custom SCXI terminal blocks who design and lay out custom circuit boards for terminal blocks. The SCXI-1381K terminal block housing kit includes the unassembled components you need to build a custom SCXI terminal block. Your kit contains all the following mechanical components of an SCXI terminal block:

- The metal enclosure
- Front and back panels
- Connectors, not including the circuit board
- A 96-position, right-angle DIN connector for attaching to your custom circuit board, if needed

What You Need to Get Started

To use your SCXI-1381K to build a custom SCXI terminal block, you need the following:

- SCXI-1381K terminal block housing kit, containing the following:
 - *SCXI-1381K Terminal Block Housing Kit Installation Guide*
 - Terminal block base
 - Terminal block cover
 - Strain-relief bar
 - Two self-adhesive rubber foam strips
 - Two 6–32 by 5/8 in. screws
 - One number 4 eyelet solder-lock terminal
 - One 4–40 by 1/4 in. panhead screw

- Two 4–40 by 0.29 in. shoulder screws
- Two 4–40 captive cover screws
- Two thumbscrews
- One 96-position, right-angle female DIN connector
- One identification label
- One self-adhesive front-panel overlay

Number 1 and 2 Phillips-head screwdrivers

Installing the Circuit Board into the SCXI-1381K

You need to design and assemble your custom circuit board before you install it into the terminal block base. When you are designing the custom circuit boards, use the dimensions in Figures 1 and 2 as a guide. The diagrams show detailed dimensions to design circuit boards for use with the SCXI-1381K terminal block enclosure.

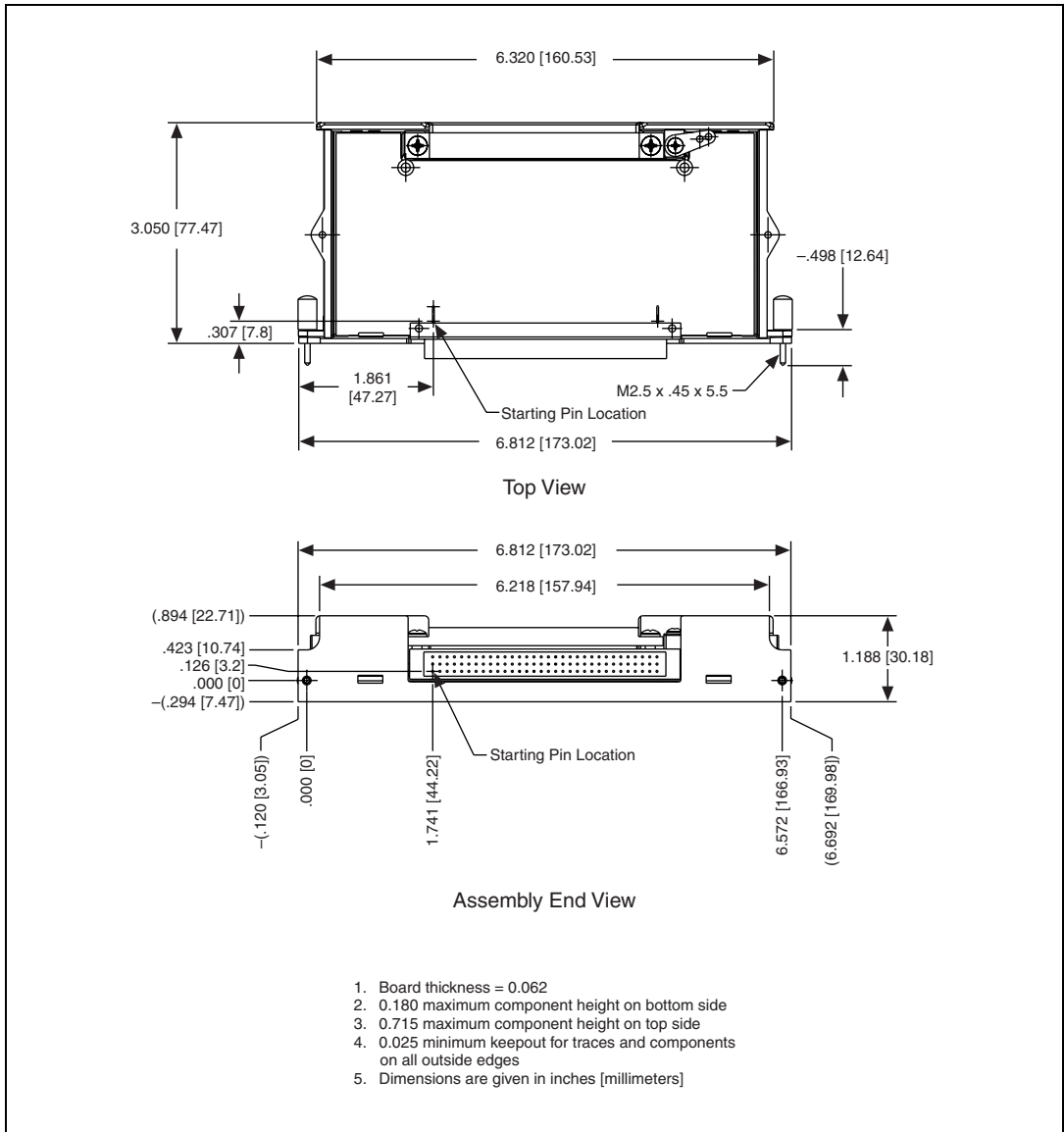

Figure 1. SCXI-1381K Dimensions

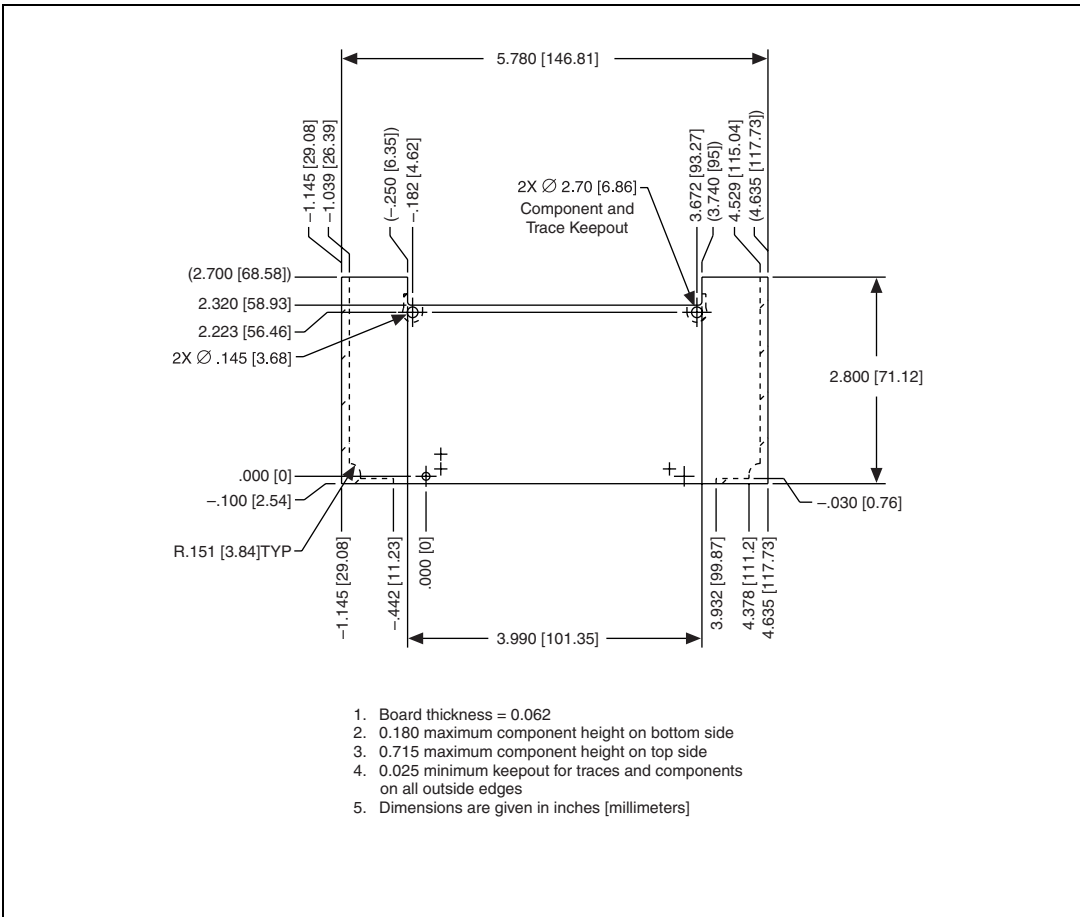

Figure 2. Circuit Board Dimensions

After assembling the circuit board, perform the following steps to install the custom circuit board into the SCXI-1381K terminal block, referring to Figure 3 when necessary:

1. Attach one self-adhesive rubber foam strip to the bottom of the strain-relief bar. Attach the other foam strip within the strain-relief opening of the terminal block base.
2. Fasten the strain-relief bar to the terminal block base with the two 6–32 by 5/8 in. screws using a Number 2 Phillips-head screwdriver.
3. Use a Number 1 Phillips-head screwdriver to attach the Number 4 eyelet solder-lock terminal to the terminal block base with the 4–40 by 1/4 in. screw.
4. Attach the self-adhesive front-panel overlay to the base.
5. Lay your circuit board in the terminal block base.

6. Use a Number 1 Phillips-head screwdriver to attach the circuit board to the base with the two 4-40 by 0.29 in. shoulder screws.
7. Attach the terminal block cover to the terminal block base with two 4-40 captive cover screws. These screws also ground the cover.



Note

The 4-40 captive cover screws become captive screws once they are installed for the first time.

8. Attach the thumbscrews.

The assembly is complete.

Use the thumbscrews to attach the assembled terminal block to an SCXI module. As needed, connect signal wires to your custom circuit board.

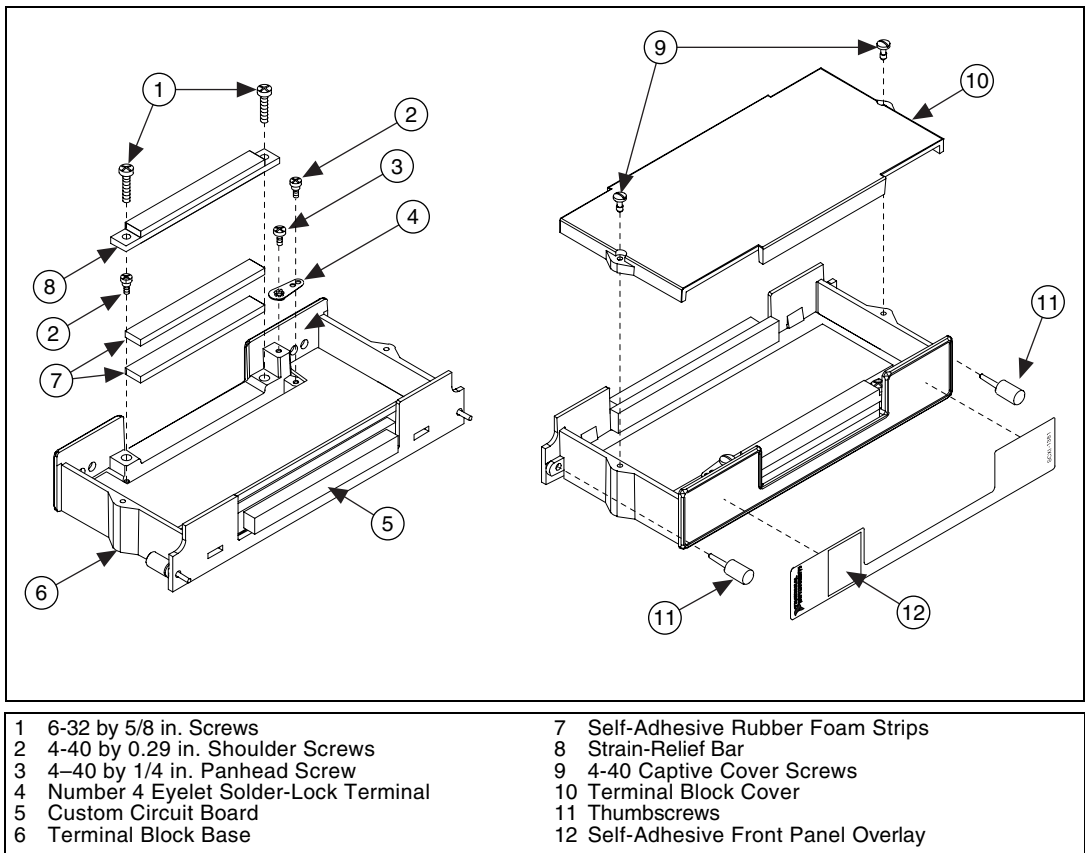

Figure 3. Parts Locator Diagram